

H40

Multipurpose Gel-Adhesives,
structural, thixotropic &
fluid, with variable flexibility

kerakoll

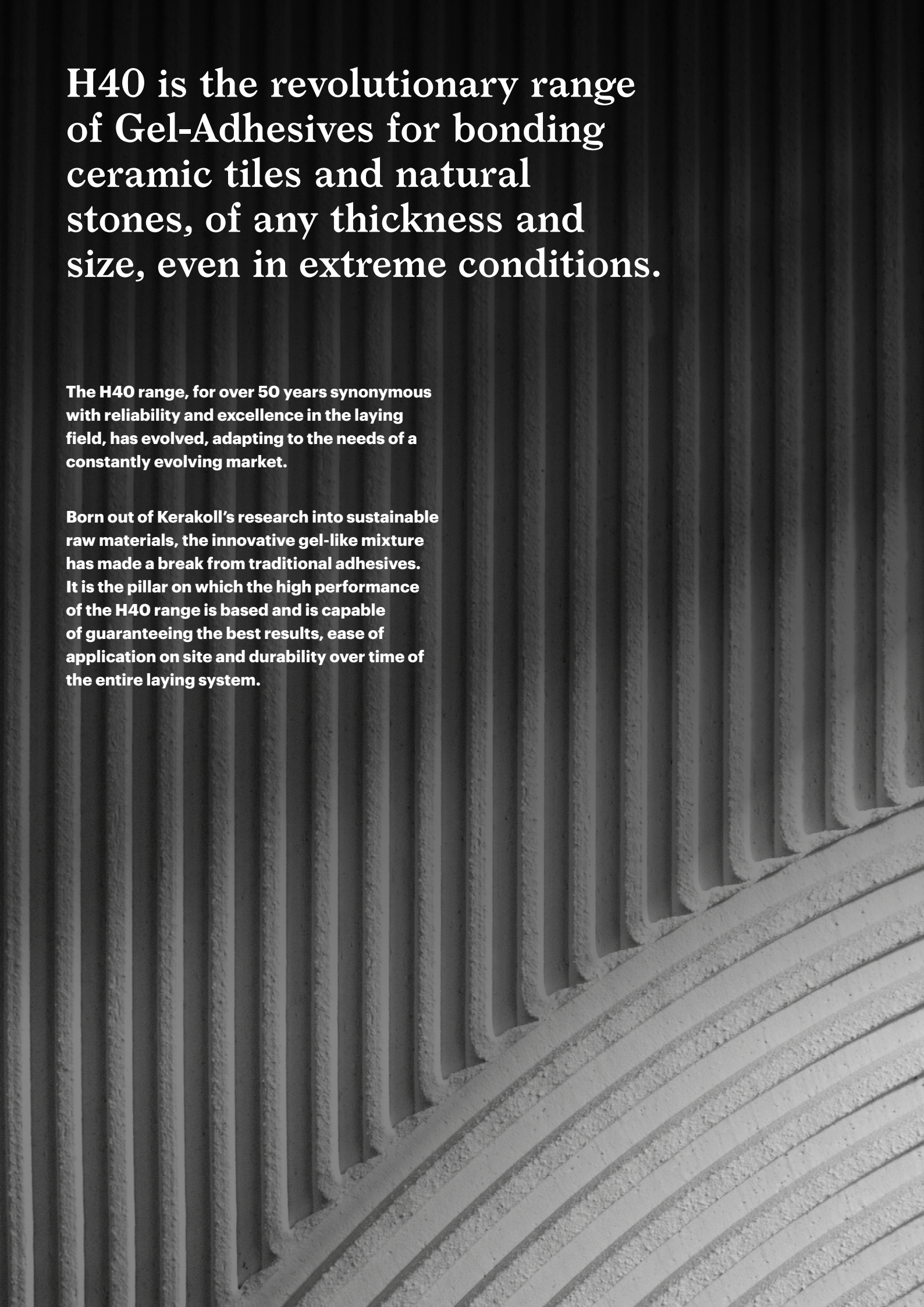

H40 is the revolutionary range of Gel-Adhesives for bonding ceramic tiles and natural stones, of any thickness and size, even in extreme conditions.

The H40 range, for over 50 years synonymous with reliability and excellence in the laying field, has evolved, adapting to the needs of a constantly evolving market.

Born out of Kerakoll's research into sustainable raw materials, the innovative gel-like mixture has made a break from traditional adhesives. It is the pillar on which the high performance of the H40 range is based and is capable of guaranteeing the best results, ease of application on site and durability over time of the entire laying system.

H40 Gel-Adhesives.

Professionalism behind every
laying system.

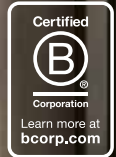

Kerakoll presents its innovative range of H40 structural Gel-Adhesives with variable flexibility specially designed to meet the technical needs of today's building sites. The best workability as always, combined with excellent and calibrated performance to ease and support the work of laying professionals and construction firms in all kinds of laying systems. For a highly professional laying.

kerakoll

H40 Gel-Adhesives: tested for the entire life cycle of the laying system.

The durability of H40 Gel-Adhesives is tested by means of strict internal protocols including the SAS (Shock Absorbing System) methodology, specially designed by Kerakoll researchers to simulate the life of the tiled system during its entire life cycle. Exceeding the limits imposed by the standards, samples are subjected to cyclic physical-chemical, thermal and mechanical stresses, repeated over time and simultaneously, by pushing the tests considered critical to the extreme and monitoring the exceeding of the requirements in the long term. The H40 range overcomes every challenge and guarantees unparalleled durability even under extreme conditions, ensuring maximum reliability of Kerakoll laying systems over time.

H40 Gel-Adhesives have numerous advantages:

→ **Workability**

Designed for the laying professionals to simplify choices, eliminate risks and improve the quality of their work.

→ **Performance**

Guaranteed technical performance, tested with severe strain cycles that reproduce the actual stress conditions to which the tiled surface is subjected.

→ **Durability**

Long-lasting and therefore more sustainable products in relation to their entire life cycle thanks to the careful selection of raw materials.

→ **Safety**

With very low VOC emissions, non-toxic, safe for the health of laying professionals and end users.



Gel-Technology: the revolution in the laying of ceramics and natural stones.

Gel-Technology is an exclusive technical-scientific research that studies the behaviour of natural elements and eco-friendly raw materials through their interactions and the control of rheology. It formulates innovative solutions that ensure the perfect balance between final performance and ease of use on site. A skilful work on the mix-design, achieved through constant collaboration with our suppliers and the most advanced research institutes, to identify the most innovative components and set new quality standards in terms of both performance and application, focusing on the overall durability of the laying system.

A sustainable approach linked to the entire life cycle of the product, ensuring that laboratory results are replicated on the building site and maintained when the product is used. Constantly evolving research to ensure the new state of the art in laying.

GEL
TECHNOLOGY



The Gel formula: the perfect balance between workability and performance.







H40 Gel-Adhesives originate from the identification of six parameters linked to the product's fundamental characteristics of workability and performance.

At the formulation stage, Kerakoll researchers carry out numerous tests to maximise and balance all these parameters. Only after a long process of laboratory research and on-site validations in collaboration with laying professionals was the perfect gel formula born.

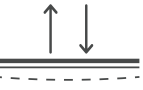

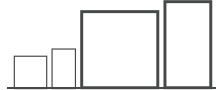
H40 Gel: the new generation of highly flexible Gel-Adhesive.

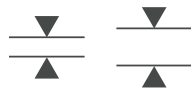
H40 Gel is the Gel-Adhesive designed for building sites requiring highly flexible adhesives. Ideal for all kinds of formats, it offers an optimal solution especially for contemporary projects where large format slabs are frequently used. H40 Gel is an extremely easy-to-work product that guarantees extended correction times to facilitate a state-of-the-art installation, even in unfavourable or time-consuming laying conditions.

| | | | | |
|--|---|--|---|--|
| Type 4 TS1 IS 15477:2019 | C2 TE S1 EN 12004 |  highly flexible |  indoor/outdoor use |  suitable for large formats |
|  ≈ 1.2 kg/m² coverage x mm of thickness |  heavy traffic |  from 3 mm to 15 mm |  ≈35 min. open time |  pot life ≈ 6 hours |

- **High adhesion and deformability**
- **Excellent wettability and workability**
- **Variable rheology**
- **Ideal for large formats**







Grey

White

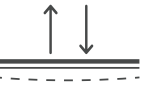

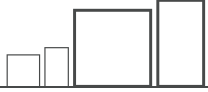
H40 Tech: the Gel-Adhesive ultra-flexible with superior adhesion.

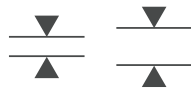
H40 Tech is the Gel-Adhesive designed to meet the needs of the most technologically advanced building sites, where materials and operating conditions require high system flexibility. Thanks to its features, H40 Tech is ideal for working in complete safety on the most flexible surfaces and in operating conditions involving complex stresses.

| | | | | |
|---|--|---|--|---|
| Type 4 TS2 IS 15477:2019 | C2 TE S2 EN 12004 |  highly flexible |  indoor/outdoor use |  ideal for facade |
|  suitable for large formats |  coverage x mm of thickness ≈ 1.2 kg/m² |  from 3 mm to 15 mm |  ≈40 min. open time |  pot life ≈ 6 hours |

- **Superior levels of adhesion and flexibility, maximum safety on difficult substrates**
- **Excellent workability**
- **Long adjustable time**
- **Ideal for laying large-format slabs**
- **Suitable for laying on facades**

Grey

White

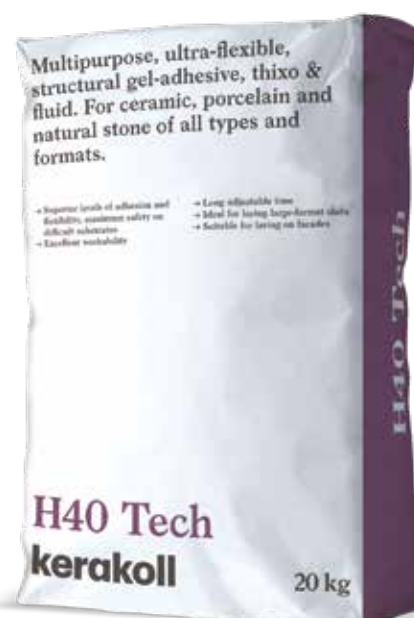

H40 Extreme: the Gel-Adhesive for extreme applications.

H40 Extreme is the Gel-Adhesive that revolutionises the world of reactive adhesives. Two-component, with unique workability and fluidity, and no vertical slip, it is the ideal solution when extreme adhesion and flexibility are required.

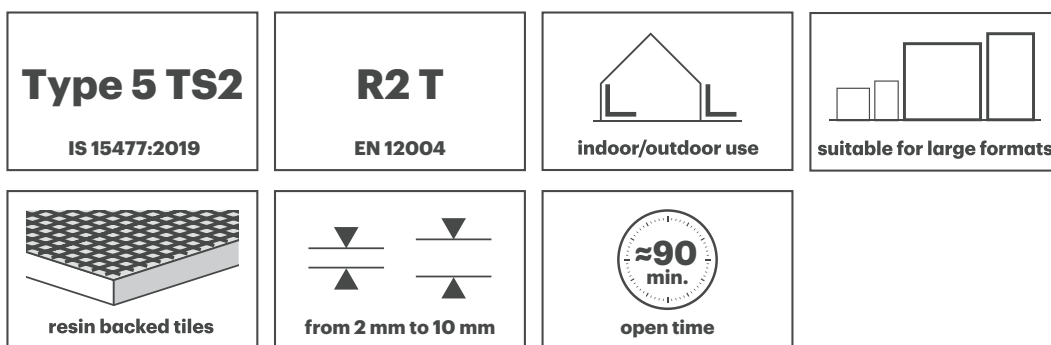

→ **Extreme flexibility**

→ **Extreme adhesion**

→ **Extreme workability**

→ **High strength Polyurethane base adhesive**

White



H40, the complete range of multipurpose Gel-Adhesives.



Gel-Adhesives of the H40 range are the ideal solution for every need because they ensure performance levels exceeding standard limits.

→ **Guaranteed results on every substrate and every laying material.**

→ **The universal solution for the most varied project and site requirements.**

| Substrates | Preparation |
|-----------------------------|--|
| concrete | checking absorption |
| cement-based screed/plaster | checking absorption and condition of substrate |
| existing tiles | cleaning and drying |
| metal* | cleaning of substrate |
| plywood* | cleaning of substrate |

It is essential to check and properly prepare the substrate to guarantee maximum laying performance.

* With H40 Extreme.

Thixo & fluid Gel-Adhesives.

H40 Gel-Adhesives are thixotropic adhesives with variable rheology; soft and workable when applied with a spreader, they maintain their thickness unchanged under the weight of the tile. This characteristic, obtained without compromising workability, eases the laying specialist's task of creating perfectly even surfaces.

Suitable for all types of substrates, they guarantee no slip of the tile in vertical applications.

- **They support the weight of the tile while maintaining shape and thickness without slumping.**
- **They make it easy to create an even surface without tile lippage.**
- **They guarantee no vertical slip, allowing wall tiles to be laid from the top down as well as from the bottom up.**



Gel-Adhesives with full wettability.

The Gel-Adhesives fully wet the back of the tile and make it easier to obtain a solid bedding. Creating a compact adhesive layer between the substrate and the tile, which maximises the contact surface between the two elements without any void, guarantees perfect and long-lasting adhesion.

The uniform and monolithic layer of the H40 Gel-Adhesives ensures a correct distribution of loads, avoids breakage and helps to maintain the performance level of the system even in difficult working conditions.

The extended open time allows to work unhurried, avoiding skin forming or thickening.

- **Make it easier to solid bed the tiles.**
- **Ensure perfect laying with both traditional formats and large format slabs.**
- **Limit the formation of voids under the tile.**
- **Do not allow a skin to form or thickening.**



A simple pressure is enough to obtain a solid bedding under the tile.



Structural Gel-Adhesives with variable flexibility.

The H40 range features structural Gel-Adhesives, capable of guaranteeing monolithic adhesion to the elements making up the system and of uniformly transferring the stresses to which the tiling is subjected.

Thanks to the introduction of special high-performance additives that increase their flexibility, the Gel-Adhesives are tested for calibrated resistance to all stresses acting on the tiled system.

- **They create a structural bond between the substrate and the tile which will ensure durability over time.**
- **Suitable for deformable substrates such as plywood and metal.**
- **The inclusion of additives that improve flexibility characteristics does not compromise workability, ensuring the best performance on site.**



Flexibility resistance tests.



Complete solutions for all applications.

Tiled surfaces made with Kerakoll laying systems have unique technical and aesthetic performance and guarantee the best quality, maximum safety and high living comfort.



→ **Large size**

The thixo & fluid mix of the H40 Gel-Adhesives is suitable for all building site requirements; it guarantees total wettability of the back of the tile, which is fundamental to obtain a solid bedding when laying large formats. The extreme fluidity under the spreader and the extended open time ensure easy working conditions and maximum safety even when laying large ceramic slabs whose procedures, such as handling and double spreading, need extended times for laying professionals.



→ **Swimming-pools**

The superior wettability of the H40 Gel-Adhesives creates a monolithic bonded system in swimming pools as well, ensuring that performance is maintained even when in constant contact with water. The thixo & fluid mix allows unique workability on walls and floors, in combination with all commonly used swimming pool materials.



→ **Facades**

H40 makes it easy to achieve a solid bedding of the tiles and no vertical slip, even when laying on facades, with all formats and thicknesses. Extended open time enables safe laying even in case of large slabs. The use of H40 on facades guarantees as well shear strength against significant temperature changes typical of these systems.



→ **Waterproofing Systems**

The perfect fusion between H40 Gel-Adhesives and Kerakoll range of waterproofing solutions gives birth to the Laminati systems. These truly monolithic systems are able to guarantee the absolute resistance to water of the entire tiled system, both indoors and outdoors. Package tests of the whole system and perfect compatibility between all its elements, studied down to the smallest detail, guarantee reliable and long-lasting results.



→ **Heavy traffic**

In areas subject to heavy traffic it is essential to use an adhesive with total wettability that facilitates a solid bedding of the tiles and the creation of a monolithic tiled surface.

H40 provides a structural-type adhesion, capable of distributing stresses and absorbing shear actions generated by dynamic loads.



→ **Heated floors**

Gel-Adhesives are tested to respond perfectly to shear stresses caused by substrate expansion generated by temperature changes in underfloor heating systems. In addition, their calibrated flexibility allows for safe installation in the case of compressible substrates, enabling installation in variable thicknesses with lowered systems.

Our commitment to build a conscious future.



For Kerakoll, being a B Corp-certified company means generating every day value through our projects, protecting the environment, people and communities.
Building better places to live.



Learn more about our commitment.

kerakoll

Respect for the environment and technological innovation.

Kerakoll is a certified B Corp Benefit Company; the award is issued by the international body B Lab to organisations committed to high standards of social and environmental performance. Among the most appreciated aspects that emerged from B Corp's assessment of Kerakoll were the reduction in the use of chemicals, low emissions of Volatile Organic Compounds (VOC), the use of recycled materials and sustainable logistics favouring intermodal transport systems. The H40 range respects these principles and combines sustainable quality with the highest performance.

→ **Low emissions of volatile organic compounds**

H40 Gel, Tech and Extreme comply with the most stringent emission limits set by the GEV-EMICODE® mark and are thus classified as EC1 Plus. In the manufacture of our products, we seek to minimise the emission of chemical contaminants, thus guaranteeing better indoor air quality, both for application professionals and building occupants.

→ **Sustainable packaging**

The new H40 Extreme buckets are made of recycled plastic; they save resources and guarantee the same performance and quality standards as virgin plastic packaging.

→ **Transparent communication**

All products from the H40 range are analysed via an EPD study - Environmental Product Declaration - which allows us to measure and identify how to improve our products in terms of sustainability.

→ **Long-term durability**

The Gel-Adhesives are tested to withstand stresses that replicate the entire life cycle of the installation, ensuring durability and reliability over time of the entire flooring system.

A high-performance adhesive contributes significantly to the sustainability of a building, as it can minimise or avoid the need for future repairs, maintenance or renovations.

kerakoll



kerakoll.com